

# Micro Air-Core (MAC) Movement

P/N 2022-7XX



## General Description

The Simco MAC movement is a precision miniature meter movement developed and patented for use in automotive gauge applications. The MAC movement's uniquely small size allows superb flexibility and ease of installation. The MAC movement is based on gearless technology. These movements are commonly used in automotive vehicles to drive speedometers, tachometers and auxiliary gauges. The MAC movement is built using two coils placed at a 90° orientation to each other. A magnetized disc floats in the middle of the coils and responds to the magnetic field generated by the vector sum of the voltage applied to each coil. The disc has a shaft attached to it that protrudes out of the assembly. A pointer indicator can be attached to this shaft and in conjunction with a separate printed scale displays the vehicle's speed, engine's speed or other driver information.

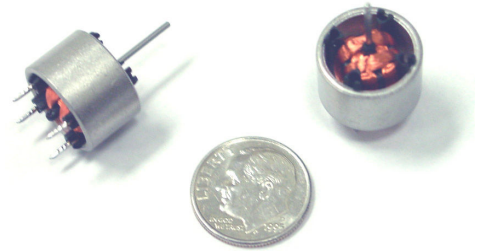

## Features

- Extremely small package (size of a dime)
- Low current consumption
- High degree of accuracy
- No 'power-on' gear noise
- No springs or gears
- Option of front or rear PCB mounting
- Rugged bearings provide vibration resistance
- Built-in damping with wide range of damping characteristics
- Variable shaft lengths/styles available
- Easily integrated into existing products

## Typical Applications

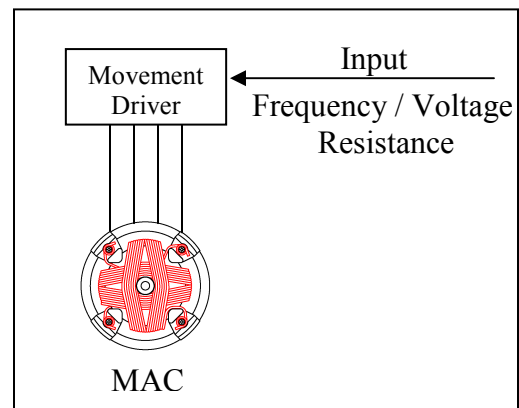
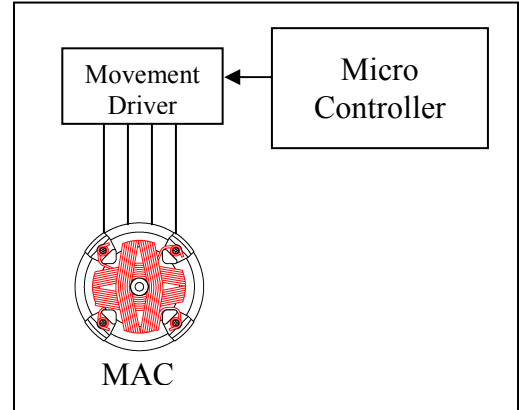

Outline Drawing:

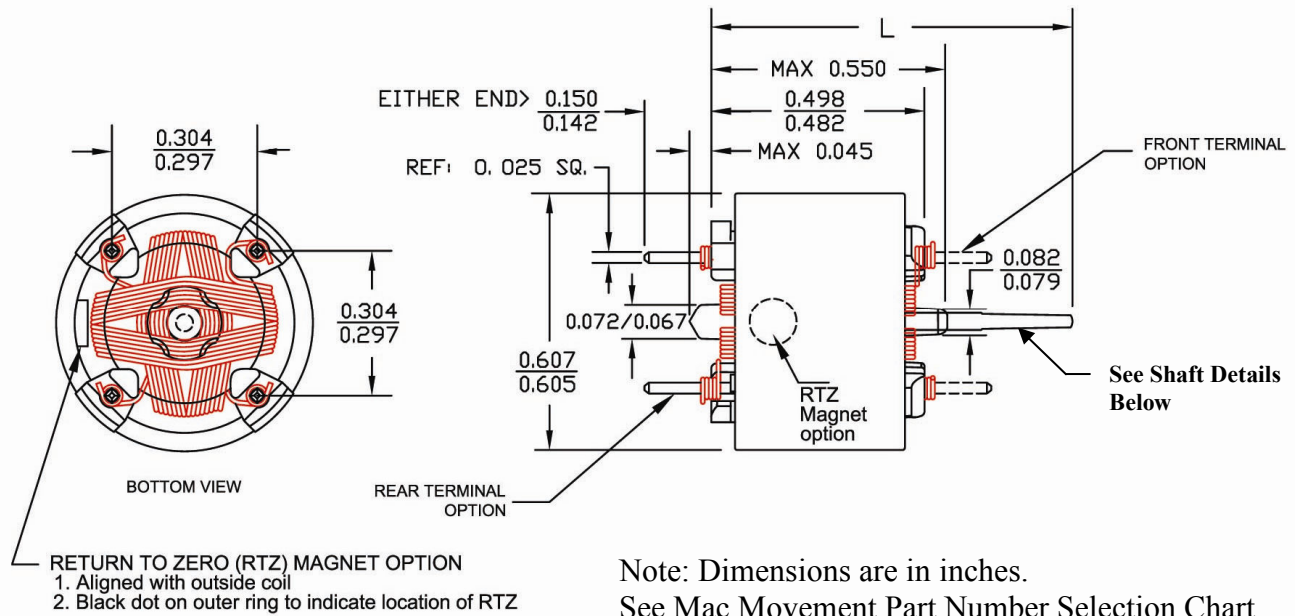

**Straight Shaft Details**

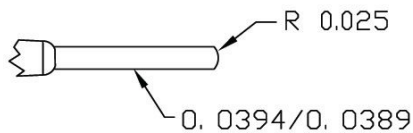

**Tapered Shaft Details**

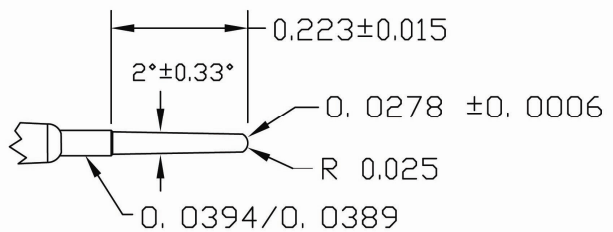

Note: Straight Shafts are commonly used with Plastic Pointers and Tapered Shafts are commonly used with Aluminum Pointers.

**Electrical Drive & PCB Notes:**

- Movement may be placed in any rotation (Exception: Return to Zero option).
- Movement will rotate clockwise from 0 - 360 degrees as shown in electrical PCB layout.

Pin voltage based on movement angle

Differential voltage (Cos+ - Cos-) = Cos(angle) x Vss  
 Differential voltage (Sin+ - Sin-) = Sin(angle) x Vss

Example: Vss = 10 volts, angle desired = 60 degrees

Diff. Voltage (Cos+ - Cos-) = cos(60)x10 = 5V  
 Diff. Voltage (Sin+ - Sin-) = sin(60)x10 = 8.66V

**Electrical PCB Layout**

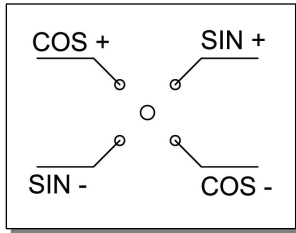

**Recommended PCB Hole Layout**

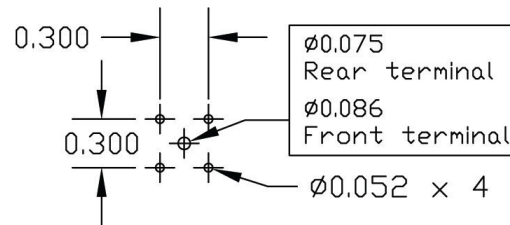

Note: Units are in inches.

**Electrical and Mechanical Characteristics:**

Parameter	Test Conditions	Min.	Typ.	Max.	Units
Angle of rotation		0		360	Degree
Weight			7.1		gram
Operating temperature		-40		105	° C
Coil resistance	25° C (off condition)	209	220	235	Ohms
Continuous Coil voltage				12	V
Peak torque	9V			5	gm-cm
Linearity	Full scale			±1	Degree
Hysteresis (no fluid)	Full scale			±1	Degree
Hysteresis (fluid filled)	See Damping Application Section				Degree
RTZ Linearity	Full scale with RTZ		±8		Degree
Forces allowable on shaft:					
Axial (push) force	Rear Terminal MAC			40	lb
Axial (pull) force <sup>1</sup>	Rear Terminal MAC			12	lb
Axial (push) force <sup>2</sup>	Front Terminal MAC			12	lb
Axial (pull) force	Front Terminal MAC			40	lb

1 Adding support over the center of a rear terminal MAC when upward axial force is applied to the shaft will allow a greater maximum force up to 40lbs. Note the failure for an unsupported MAC is created when the soldered MAC pins pull from the MAC bobbin as maximum force is applied to the shaft.

2 Adding support under the center of a front terminal MAC when downward axial force is applied to the shaft will allow a greater maximum force up to 40lbs. Note the failure for an unsupported MAC is created when the soldered MAC pins pull from the MAC bobbin as maximum force is applied to the shaft.

**Mac Movement Part Number Selection Chart:** (See further in document for damping criteria)

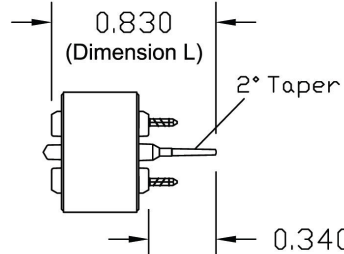
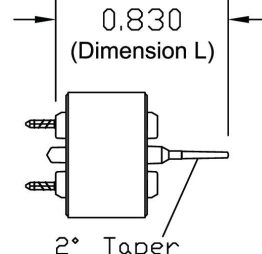
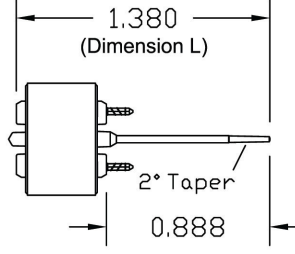
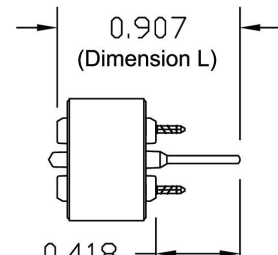
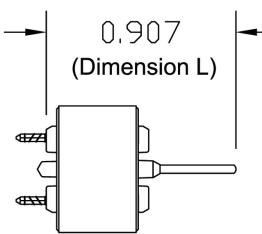
Front Terminal w/Tapered Shaft	Rear Terminal w/Tapered Shaft	Front Terminal w/ 1.3" Taper
2022-710 Light Damping 2022-711 Standard Damping 2022-714 Standard Damping w/ RTZ 	2022-701 Light Damping 2022-709 Standard Damping 2022-702 Heavy Damping 	2022-716 Standard Damping 2022-717 Standard Damping w/ RTZ 
Front Terminal w/Straight Shaft	Rear Terminal w/Straight Shaft	Special Wound movements
2022-715 Light Damping 2022-704 Standard Damping 2022-705 Standard Damping w/ RTZ 2022-712 Heavy Damping 2022-713 Extra Heavy Damping 	2022-707 Light Damping 2022-706 Standard Damping 2022-708 Standard Damping w/ RTZ 2022-703 Heavy Damping 	Special wound and assembled movements are available at request. Many movements are already available for direct sender and single voltage inputs.  Call for more information.

**MAC Movement Part Number Summary Chart:**

MAC Movement P/N	Shaft Type	Terminal	Damping Fluid	Return to Zero (RTZ)
2022-701	Tapered	Rear	Light	No
2022-702	Tapered	Rear	Heavy	No
2022-703	Straight	Rear	Heavy	No
2022-704	Straight	Front	Standard	No
2022-705	Straight	Front	Standard	Yes
2022-706	Straight	Rear	Standard	No
2022-707	Straight	Rear	Light	No
2022-708	Straight	Rear	Standard	Yes
2022-709	Tapered	Rear	Standard	No
2022-710	Tapered	Front	Light	No
2022-711	Tapered	Front	Standard	No
2022-712	Straight	Front	Heavy	No
2022-713	Straight	Front	Extra Heavy	No
2022-714	Tapered	Front	Standard	Yes
2022-715	Straight	Front	Light	No
2022-716	1.3" Tapered	Front	Standard	No
2022-717	1.3" Tapered	Front	Standard	Yes

### Movement Damping Application Notes:

#### Light Damping:

- Max 1° of Hysteresis Lag
- One Drop of 5,000 cst Silicon Fluid

Light damping means that the pointer moves at the quickest response to the desired position. All of our MAC movements are inherently accurate so the light damping is highly suitable for applications where vibration or a heavy mass pointer is not a concern.

#### Standard (MEDIUM) Damping:

- Max 2° of Hysteresis lag
- Full bobbin of 5,000 cst Silicon Fluid

Medium damping is our most common configuration; the pointer moves fast and stays steady. It is often used in applications where vibration is of some concern such as automobiles or motorcycles.

#### Heavy Damping:

- Max 5° Hysteresis Lag
- Full bobbin of 10,000 cst Silicon Fluid

Heavy damping means that the pointer moves slower but it is under more control for applications that see a lot of vibration such as highway trucks, NASCAR, and off road vehicles.

#### Extra Heavy Damping:

- Max 7° Hysteresis Lag
- Full bobbin of 20,000 cst Silicon Fluid

Extra heavy damping means that this movement holds a steady reading in the most demanding environments. This movement is particularly well suited to high vibration applications such as speed boats, and heavy construction machinery.

**Return To Zero (RTZ) Application Notes:**

The table below indicates the pointer movement when power is turned off utilizing the Return To Zero (RTZ) option and referenced from starting position at Cos 0 on the coils. Reference the picture to the right of the table for RTZ positions.

MAC Type	RTZ Position	Power off Direction	Degrees From Cos 0
Rear Terminal	1	---	0
Rear Terminal	2	Clockwise	75
Rear Terminal	3 *	Unstable	180
Rear Terminal	4	Counterclockwise	75
Front Terminal	1	Clockwise	75
Front Terminal	2 *	Unstable	180
Front Terminal	3	Counterclockwise	75
Front Terminal	4	---	0

**RTZ Position (Top View)**

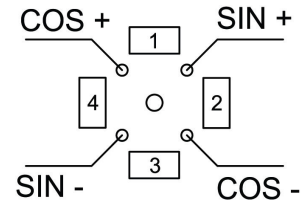

\* Not recommended when using pointer stops.  
Accuracy of pointer movement in off condition is  $\pm 10$  degrees.

**Recommended movement driver:**

- ON semiconductor CS8190



Simco, Ltd.  
1 DeMille Rd.  
Lapeer, MI 48446

For additional information please contact Simco Ltd at:  
Phone: 810-245-0188  
Email: [info@simcoltd.com](mailto:info@simcoltd.com)  
Visit us at [www.SimcoLtd.com](http://www.SimcoLtd.com)

Product is covered under the following patents: 5686832,  
6046583, and 6323637